

THIS DRAWING IS THE PROPERTY OF PRIMARY FLUID SYSTEMS INC. FROM WHICH A WRITTEN CONSENT FOR APPROVAL SHALL BE REQUIRED PRIOR TO COPYING.

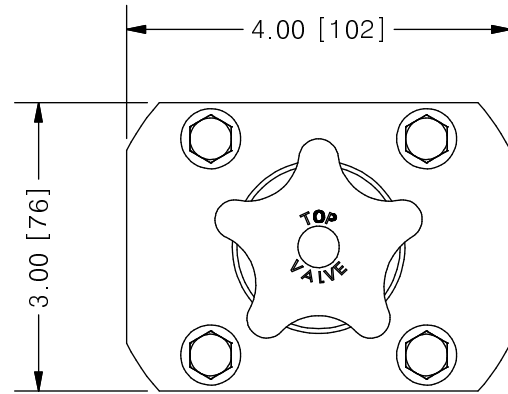

TOP VALVE® TVP PRESSURE RELIEF VALVE

NO.	NAME	DESCRIPTION
1	MAX ALLOWABLE OPERATING TEMPERATURE	180°F (82°C)
2	MAX ALLOWABLE OPERATING PRESSURE	150 PSIG @ 70°F
CONNECTIONS		
3	SIZE: INLET/OUTLET PORTS	1"
4	SIZE: RELIEF PORT	1"
5	CONNECTION TYPE	NPT
MATERIALS (WETTED)		
6	BODY	316 SS
7	DIAPHRAGM	PTFE BACKED EPDM
MATERIALS (NON-WETTED)		
8	SPRING BONNET/TOP	CPVC
9	SPRING	NICKEL PLATED MUSIC WIRE ASTM A228
10	TOP/BOTTOM DISC	POLYPROPYLENE
11	BOLTS, NUTS, WASHERS	STAINLESS STEEL
12	FACTORY SET PRESSURE	50 PSIG
13	SPRING RANGE	7-150 PSIG

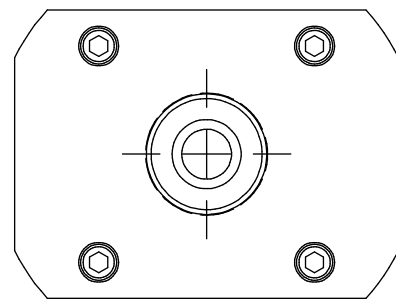
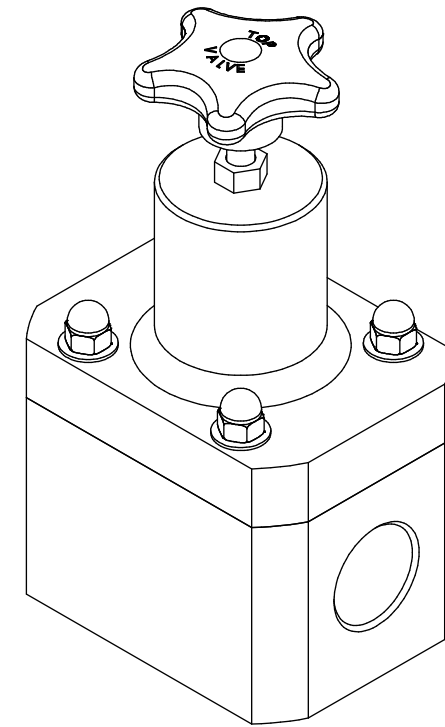
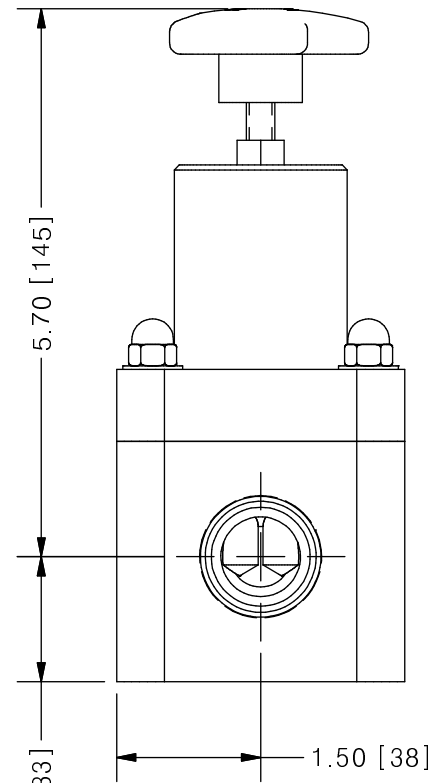
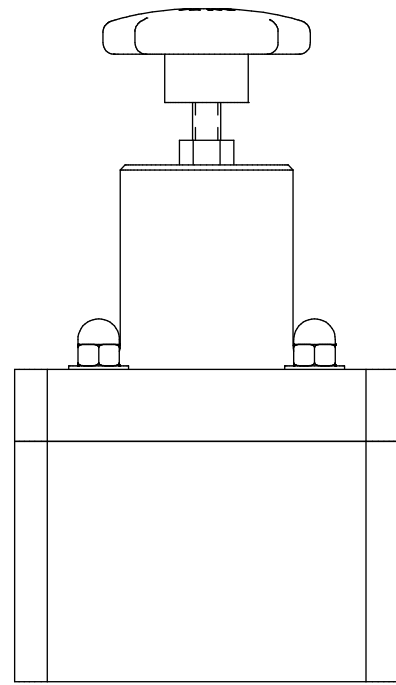

SCALE 1 : 2

PRIMARY FLUID SYSTEMS INC. 1050 COOKE BLVD, BURLINGTON, ONTARIO L7T 4A8		PROJECT: TVP	SHT: 1 OF 1	DRAWN BY: NG
TITLE: 1" PRESSURE RELIEF TOP VALVE WITH 1" NPT CONNECTIONS		DATE DRAWN: 7/27/2016	SCALE: 1 : 2	UNITS: INCH [mm]
DWG NO: TVPR10-SS_R0		MATERIAL: SEE CHART	REV# 0	
DWG NAME: TOP VALVE		APPROVED BY:	CHECKED BY:	THIRD ANGLE PROJECTION
DWG TYPE: PLANAR VIEW		DIMENSIONAL TOLERANCE 0.X = ± 0.25" 0.XX = ± 0.25" 0.XXX = ± 0.25"		

REV	DESCRIPTION	DATE	NAME
0	NEW DRAWING	--	--